

Nova-D

Multihousing RFID deadbolt



Community™ Access Management

The Nova-D is compatible with our next generation Community Access Management Software to intuitively manage authorization to common areas and residence doors, providing the highest degree of safety possible, while allowing use of a single credential to access multiple openings throughout a property.

Overview

The Nova-D RFID heavy duty deadbolt features the latest security conveniences for multihousing operations. Ideal for new applications or as a replacement for existing mechanical deadbolts, no touring reduces costs associated with traditional keys.

Access for the mobile minded

Developers and property managers can meet their residents' rising demands for greater digitization and connectivity with standard Bluetooth Low Energy (BLE) technology. The dormakaba BlueSky mobile access key delivery system allows for the use of smart devices as secure keys.

Low maintenance, easy install

- Sealed RFID reader
- Engineered for use in extreme environmental conditions
- Non-volatile memory prevents lock programming and audits from being erased during battery change
- Upgradeable lock firmware for future enhancements

Community-wide access control

- Single credential, single operating system to control perimeter and amenity entries
- Family of hardware includes remote readers, self-latching locks and panic device trim
- Industry standard Mifare credentials integrate with most third-party access control systems



Features

Programming audit trail	Programmed using handheld. Audited via handheld or Messenger
Date/time stamp	Real time; date and hours/minutes
Passage mode	Set by authorized credential or Messenger system. Can also be configured to perform an automated/pre-defined passage mode time
Credential expiration	Configurable expiration dates
Key override	Mechanical key or electronic override available
Feedback	Light indicators in reader
Audit memory	Up to 4,000 events
Power	Three AA batteries with approximately 18 months lifespan
Deadbolt	1" solid deadbolt
Door thickness	1 3/8" to 2" for standard product. Above 2", a special door kit must be ordered
Standard backset	2 3/8" to 2 3/4" adjustable
RFID Credentials specifications	Two credential format options available: Mifare Classic or Mifare Plus - Mifare Classic (4byte NUID): Resident Credentials (Mini), Staff (4K & 1K) - Mifare Plus: Resident Credentials (Mifare Ultralight C, 7 Byte UID), Staff Credentials (Mifare Plus S 2K, 4 Byte NUID, Mifare Plus S 4K, 4 Byte NUID)
Interrogation	Obtain key usage reports from the lock by using a handheld unit at the door, or increase efficiency by performing a remote interrogation using Messenger (optional)
Pre-registered credentials	Keys can be made up to ten days in advance without cancelling current residents
Mobile key options (BLE)	Bluetooth Low Energy (BLE) is standard. Requires the use of dormakaba BlueSky mobile key delivery system app. iOS and Android compatible
* Online configuration (optional)	Messenger Ready and Messenger Online, two way communication between software and electronic locks to monitor and manage door activity in real time

Certifications and testing

Fire rating	Listed for pre-prepared manufactured doors and certified for retrofitting on existing doors by Underwriters Laboratories for use on fire doors having up to a three-hour rating Evaluated in accordance with UL 10B and UL 10C
Florida building code	Certified in the Florida Building Code (FBC)
ANSI/BHMA	Built and tested to ANSI/BHMA Grade 2
Electronics	FCC Part 15C and CE certified to the RE Directive 2014/53/EU
Environmental operating conditions	-31°F to 151°F (-35°C to 66°C) 0% to 85% non-condensing humidity at 86°F (30°C)

Warranty

Standard factory warranty	Two years. Extended warranty options available.
---------------------------	---

Finishes

Standard finishes	Ultra Satin Chrome (U26) Ultra Oil-rubbed Bronze (U13)
-------------------	--

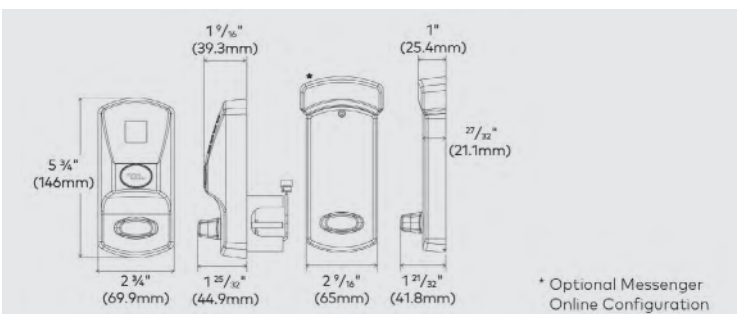

© dormakaba 2024 Information on this sheet is intended for general use only. dormakaba reserves the right to alter designs and specifications without notice or obligation.

Any questions? We would be happy to advise you.
Contact us at: 1-800-265-6630